



EKIN ENDUSTRIYEL

Shell and Tube Heat Exchangers
User Manual



Follow us on social media!



www.instagram.com/ekinendustriyel



www.facebook.com/ekinendustriyel



www.youtube.com/ekinendustriyel



www.linkedin.com/company/ekinendustriyel



www.twitter.com/ekinendustriyel



www.soundcloud.com/ekinendustriyel



www.spotify.com/ekinendustriyel



**The first condition of innovation is to question.
And the first condition of sustainable innovation is to question
constantly.**

The journey of innovation has started with a question for us too: “How can we develop value-added technologies in Turkey?”. First turning point in this long journey was the birth of MIT (Made in Turkey) brand. MIT made us the first plate heat exchanger producer of Turkey and it’s founding vision was not to become a local alternative, it was to build a high-quality brand that can compete on a global level.

While we are working towards this goal in the past 15 years, our products and processes deemed worthy for documentation by many national and international quality assessment institutions such as ISO, TSE, CE, GOST and many more. This was the natural outcome of our constant questioning of the status-quo and our desire to outperform ourselves.

New Generation Engineering

With our engineering approach that focuses on the process, not the problem, we do not just specialize in a product, we consider the entire ecosystem of that product. Ergo, we produce all the other components of a system in addition to plate heat exchangers and we focus on the constant development of engineering staff required to provide an end-to-end application.

We provide a “solution” rather than a product with our business development, presales, sales and after sales services provided by our expert engineers.

In our 15th year, we continue to grow as a solution partner for projects that need high technology in more than 60 countries with our internationally approved high-quality plate heat exchangers; components such as accumulation tanks, boilers, industrial pumps and installation materials that completes these exchangers to form a system; and complementary services provided by our expert engineer staff.



HEAT TRANSFER PRODUCTS

- Gasketed Plate Heat Exchangers
- Brazed Heat Exchangers
- Shell & Tube Heat Exchangers
- Evaporators and Condensers
- DC Fan Driven Oil Coolers
- Heat Coils
- Serpentine / Radiators / Economizers

PRESSURE VESSELS

- Water Heater Tanks
- Water Storage Tanks
- Buffer Tanks
- Expansion Tanks
- Stainless Steel Tanks
- Balance Tanks / Dirt Separators / Air Separators / Air Tubes
- Steam Separators
- Pressured Air Tanks
- Neutralization Units

INDUSTRIAL AND FOOD GRADE SYSTEMS

- Heat Stations
- Industrial Process Systems
- Dosing Systems
- Substations
- Thermoregulators
- Pasteurizers
- CIP and Hygienic Process Systems
- Hygienic Storage and Process Tanks
- Homogenizers
- Turn-key Projects

FLUID TRANSFER PRODUCTS

- Lobe Pumps
- Hygienic Centrifugal Pumps
- Gear Pumps
- Acid Pumps
- Dosing Pumps
- Air Operated Double Diaphragm Pumps (AODD)
- Drum Pumps
- Monopumps
- Centrifugal Blowers
- Roots Blowers
- Turbo Blowers

FLOW CONTROL UNITS

- Butterfly Valves
- Ball Valves
- Globe Valves
- Knife Gate Valves
- Actuators
- Check Valves and Strainers
- Thermoplastic Valves

ENERGY SYSTEMS

- Boilers
- Steam Generators
- Solar Collectors
- Chillers
- Cooling Towers

PRODUCT RANGE



Contents

Construction and Function.....	1
MIT Shell and Tube Heat Exchangers Assembly Instructions	1
MIT Shell and Tube Heat Exchangers Commissioning Instructions.....	3
MIT Shell and Tube Heat Exchangers Maintenance and Repair.....	3
Things to Consider During Shipping and Transportation.....	3
Warranty and Service.....	4



Construction and Function

Construction

Shell and Tube Heat Exchangers are produced by combining front and rear caps, inner tube bundle, fluid connection nozzles, carrying lugs and legs as seen in Figure 1.

Function

Two different fluids are directed by the principle of reverse or parallel flow without mixing with each other through the inner tube bundle and transfers its energy from one fluid to another. Figure 1.2 shows the basic flow diagram.

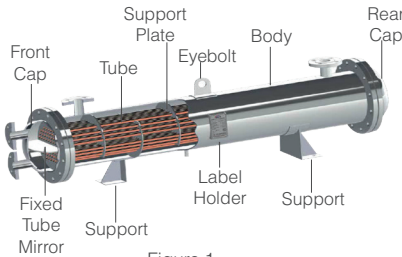

Figure 1



Figure 1.2

MIT Shell and Tube Heat Exchangers Assembly Instructions

- Exchangers with detachable coil tube bundle, should be mounted in a way that allows the coil to be removed and taken out in the heat exchanger room.
- A strainer must be placed at the inlet of the exchanger and cleaned periodically.
- The integrity of the devices on the heat exchanger (thermometer, valves, thermostatic valves, steam traps, etc.) should be checked frequently and should be repaired or replaced if malfunctioning.
- The heat exchanger must be rigidly mounted on the ground or base.
- In heat exchangers with compensator, the protection bolts should be loosened before the product is activated.
- Main line connections in heat exchangers with compensators must also have compensator in order to prevent the expansion that may occur in the product.

Lifting Instructions

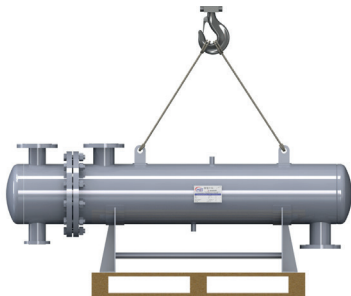

Figure 2

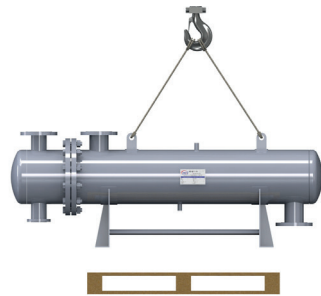

Figure 2.2



Loading and transportation should be done by connecting the eyebolts of the exchanger. During these processes, there should be no living things under and around the product.

Shell and Tube Heat Exchangers Recommended Connection Diagrams

Shell and Tube Heat Exchangers Recommended Connection Diagrams

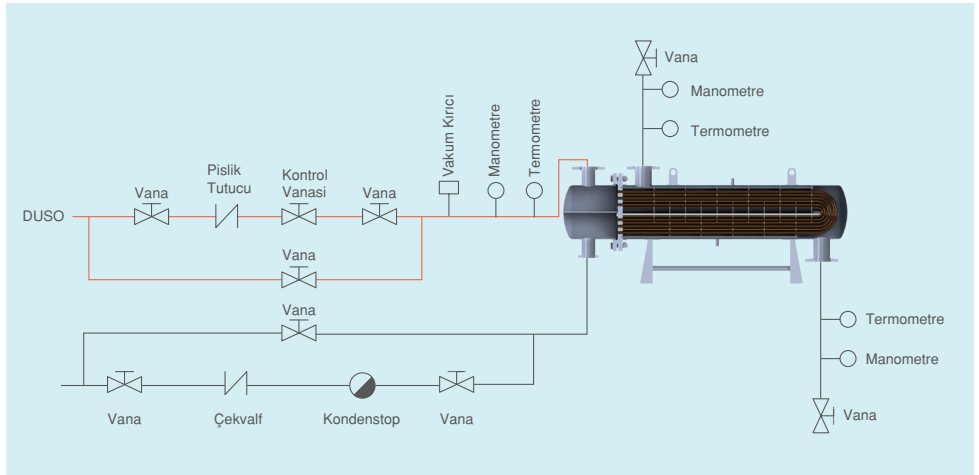

Valves may vary according to the process.

Oil Heat Exchangers Recommended Connection Diagrams

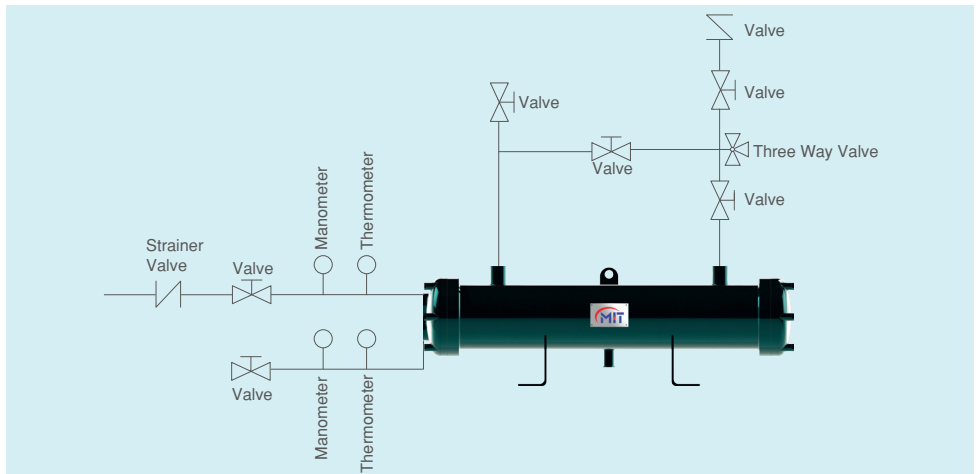



MIT Shell and Tube Heat Exchangers Commissioning Instructions

- Check that the connections of the heat exchanger are made correctly and if they are tightened.
- Check that the heat exchanger is securely fixed.
- When the heat exchanger is deployed, first cold fluid then hot fluid should be activated, and the air in the device must be evacuated.
- When the heat exchanger is to be switched off, first the hot fluid and then the cold fluid must be discharged.
- The heat exchanger's pressure should not be raised above the operating pressure.
- Exchanger fluids should be filtered.
- In order to prevent calcification in the heat exchanger pipe bundles, soft water should be used.

MIT Shell and Tube Heat Exchangers Maintenance and Repair

- Structural integrity of armatures on the heat exchanger should be checked frequently.
- The discharge valve of the heat exchanger should be opened frequently, and the deposits accumulated on the floor should be cleaned.
- Maintenance of the heat exchanger should be done at least twice a year.
- In cases where the quality of the water is not suitable (hard water and very hard water) and at high temperatures, maintenance should be done regularly at shorter intervals.
- MIT services are authorized for maintenance and repairs. The seller company is not responsible for the applications made by unauthorized personnel. Only original spare parts should be used for maintenance and repairs.

Things to Consider During Shipping and Transportation

Loading the Heat Exchanger on a Vehicle

- Heat exchanger should be loaded with a crane.
- Tailgate of the vehicle on which the heat exchanger will be installed must be opened beforehand.
- During the transportation of the heat exchanger by crane, eyebolt on the exchanger should be used (Figure 2 Pass the hook at the end of the crane boom through the carrying ring of the heat exchanger).
- Make sure that the hook pin is secure, remove the slack by slowly lifting the crane boom.
- Raise the heat exchanger slowly so that its lowest level is 30 - 40 cm above the ground.
- Avoid sudden movements that will cause the heat exchanger to shake.
- Carry the heat exchanger in this way to the side of the vehicle to be loaded.
- After the heat exchanger is brought next to the vehicle, raise it 30 - 40 cm above the body level of the vehicle and lower it properly onto the bed of the vehicle (The exchanger must be lowered onto the transport legs of the vehicle).
- Unhook the crane from the eyebolt.
- The exchanger must be transported in an upright position by using the carrying ring.
- When the heat exchanger is lifted with a crane, there should be no living things under the exchanger.

Transport of the Heat Exchanger on the Vehicle

- While the heat exchanger is being transported by a vehicle, it must be firmly attached to the vehicle, and supports must be placed around it to prevent it from slipping.
- The heat exchanger should not be transported with broken, crushed materials and living things.
- After placing the heat exchanger on the vehicle, it should be covered with a tarpaulin.
- The driver of the vehicle should avoid sudden movements that may pose any danger.

Unloading of the Heat Exchanger on the Vehicle

- The heat exchanger should not be placed at office or residential spaces. It should be placed in a separate boiler room.
- A crane should be used while lowering the heat exchanger to the boiler room.
- If it is not possible for the crane to enter the place where the heat exchanger will be used; it should be lowered to a suitable place and moved to the desired place with wheeled apparatus.

Warranty and Service

MIT shell and tube heat exchangers are under 2 (two) years warranty from the date of sale against manufacturing defects, given that all the instructions stated in this manual are followed during installation, commissioning, use and maintenance.

In order for your warranty certificate to be valid, your warranty certificate must be filled in by the Ekin Endüstriyel MIT authorized service and must be sent to production facilities of Ekin Endüstriyel Company located in Dudullu Organize Sanayi Bölgesi Des Sanayi Sitesi 107. Sk. B14 Blok No: 2 Ümraniye / İstanbul.

PROBLEMS THAT MAY OCCUR DUE TO INCORRECT INSTALLATION, MAINTENANCE, OR USAGE ERRORS OF YOUR EXCHANGER ARE NOT COVERED BY THE WARRANTY.

The minimum service life for the MIT heat exchanger specified by the ministry of industry and trade is 10 (ten) years. Manufacturer and seller companies undertake to provide service and spare parts within this period.

When you encounter any problems, you can reach Ekin Endüstriyel MIT authorized services from anywhere in the country you are in.



Notes

A series of horizontal dotted lines for writing notes.

Notes

A series of horizontal dotted lines for writing notes.



Notes

A series of horizontal dotted lines for writing notes.



CERTIFICATE OF WARRANTY



The Document's Confirmation Date And Number:

The use of this document has been authorized by T.C. Sanayi Ticaret Bakanlığı, İl Müdürlüğü in accordance with the Law No. 4077 on the Protection of Consumers and the Communiqué on the Implementation of the Guarantee Certificate put into effect based on this Law.

WARRANTY CONDITIONS

1. Warranty period starts from the delivery date of the goods.
2. All parts of the goods are covered by our company's warranty.
3. In case of malfunction of the goods within the warranty period, the time spent in the repair is added to the warranty period. The repair period of the goods is maximum 30 working days. This period starts from the date of notification to the service station of the defect goods. In the absence of service station, this period starts from the date of notification to the seller, dealer, agent, representative, importer, or manufacturer of the goods.
4. In case of malfunction of the goods within the warranty period due to material, workmanship or assembly defects, the goods will be repaired at no cost and no additional cost will be asked from the buyer under the name of changed part price or any other name.
5. Malfunctions arising from the use of the product in contravention of the provisions in the user manual are not covered by the warranty.
6. For the problems that may arise in relation to the warranty certificate can be applied to the Sanayi ve Ticaret Bakanlığı Tüketicihinin ve Rekabetin Korunması Genel Müdürlüğü.

For the product that was sold to S.C. COSIMO TECHNOLOGY
S.R.L. / Legal Entity on/...../20..... with stated model, brand and serial number,
all kinds of manufacturing and material defects are covered by the warranty of our
company for two years.

Brand: MIT _____
Model : _____
Serial No: _____

SELLER

EKIN ENDÜSTRİYEL
ISITMA-SOGUTMA
SAN. TİC. LTD. ŞTİ.

DEALER

S.C. COSIMO
TECHNOLOGY S.R.L.

END USER

NOTE: User mistakes are not covered by warranty.

www.ekinendustriyel.com



Professional System Solution Center

From our MIT professional system solution center, you can get help with problems with your pumps, heat exchangers and your system. Our solution center consisting of our expert engineers will be happy to help you.

- Domestic hot water installations.
- Central and district heating systems.
- Milk, yogurt, buttermilk heating, cooling and pasteurization systems.
- Industrial cooling and heating systems.
- Oil cooling systems.
- Energy recovery systems.
- Pool heating systems.
- Steam installations.



It is vital for your system to be designed and implemented correctly in the first installation in order to be able to operate at the desired capacity, smoothness and long life. For this reason, you can get

first-hand the technical support you need during the installation phase of your system and the problems that may arise in the business; You can reach us **24 hours +90 (216) 232 24 12 in 7 days.**

We would like to reiterate that we will be happy to share our knowledge accumulated over many years with our valued customers in order for your system to work correctly and performance.

Ekin will continue to be the best solution partner for you in all applications with all kinds of heating and cooling applications.

7/24
SERVICE
+90 850 811 04 18



/ekinendustriyel

**Follow us on
social media...**



Today; **135 points** in the world.



444EKİN
3546

 **EKİN ENDUSTRIYEL**
Isıtma-Soğutma San. Tic. Ltd. Şti.

Dudullu Organize Sanayi Bölgesi - Des Sanayi Sitesi
107. Sk. B14 Blok No: 2 Ümraniye / İstanbul / Turkey
Phone: +90 216 232 24 12 **Fax:** +90 216 660 13 08
info@ekinendustriyel.com - www.ekinendustriyel.com

