



EKİN ENDÜSTRİYEL

**AIROO HG Series Roots Blower  
User Guide**

**AIROO**

# Follow us on social media!



[www.instagram.com/ekinendustriyel](http://www.instagram.com/ekinendustriyel)



[www.facebook.com/ekinendustriyeltr](http://www.facebook.com/ekinendustriyeltr)



[www.youtube.com/Ekin Endüstriyel](http://www.youtube.com/Ekin Endüstriyel)



[www.linkedin.com/company/ekinendustriyel](http://www.linkedin.com/company/ekinendustriyel)



[www.twitter.com/ekinendustriyel](http://www.twitter.com/ekinendustriyel)



**EKIN ENDÜSTRİYEL**  
Isıtma-Soğutma San. Tic. Ltd. Şti.





## Sustainable Innovation, Quality Standardization and Dynamism

Ekin has entered Turkey's sector of the imported plate heat exchanger, with their customer-focused vision and dynamic. Ekin has expanded into new and upcoming investments. One of the main steps was gaining the identity of being a producer. Ekin has started the production of plate heat exchangers with the brand of "MIT". We have grown in the philosophy of quality, through initially adapting to ISO Quality Management.

MIT plate heat exchangers have now become a solution to engineering problems in the world market and have grown through an expansion of franchises.

## Engineering Approaches, Integrated Solutions

Ekin has expanded into the production of components, sales, and after-sales service by employing expert engineers. The factors that guided Ekin to success are their exceptional customer service to the needs and wants of consumers, modern facilities, and becoming partners to projects that involve high-end technology.

Ekin is an expert company which has a wide product range which includes plate heat exchangers, accumulation tanks, water heater tanks, installation, and its service group and submit competitive advantages to mechanical installation sector in Turkey and all around the world.



# APPLICATION FIELDS

## HEAT TRANSFER PRODUCTS



- Gasketed Plate Heat Exchangers • Brazed Heat Exchangers • Shell&Tube Heat Exchangers • Air Fan Oil Cooler • Economizers • Coils and Radiators

## PRESSURE VESSELS



- Water Heater Tanks • Water Storage Tanks • Buffer Tanks • Expansion Tanks • Stainless Steel Process Tanks • Balance Tanks / Dirt Separators / Air Separators • Pressured Air Tanks • Neutralization Tanks • Air Tubes • Steel IBC Tanks with ADR

## COMPLETE SYSTEMS UNITS



- Heat Stations • Steam Package Systems • Special Designed Systems • Dosing Systems • Substations • Thermoregulators

## FOOD GRADE SYSTEMS



- Pasteurizers with plate heat exchangers • Hygienic Pasteurizers with Shell & Tube Heat Exchangers • Cheese and whey Systems • UHT - Sterilization Systems • CIP Systems • Hygienic Storage and Process Tanks • Homogenizers • Standartization Systems • Evaporators • Turn-key Projects

## FLUID TRANSFER PRODUCTS



- Lobe Pumps • Hygienic Centrifuge Pumps • Turbo / Roots / Centrifuge Blowers • Drum Pumps • Acid Pumps • Dosing Pumps • Monopumps • Air operated Double Diaphragm Pumps (AODD)

## VALVES



- Thermoplastic Valves • Plastomatic Valves

## ENERGY SYSTEMS

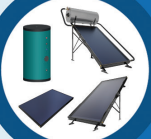

- Solar Collectors • Water Heater Tanks for Solar

## CONTENT

Main Application and Features .....	1
Operation Requirements .....	1
Working Principle and Structure.....	2
Installation & Piping.....	4
Lubrication Oil.....	5
Operation Methods .....	6
Maintainance & Check.....	7
Failure Analysis .....	8
Accessories .....	8

## MAIN APPLICATION AND FEATURES

### Main Application

HG series roots blower is widely used in electric power, oil, chemical, metallurgy, steel, food, textile, paper, dust collection, aquaculture, waste water treatment, pneumatic conveying etc. The conveying medium is clean air.



This series roots blower can't be used for conveying flammable, explosive, and poisonous gas.

### Main Features

HG series roots blower includes inlet silencer (with filter inside), outlet silencer, flexible joint, pressure gauge, safety valve, check valve, vibration absorber, and some other accessories, tight structure, better design and good outlooks, easily for installation.

HG series roots blower is on the basis of American HI-BAR company M series roots blower, and using our own design. It has a great improvement at structure and performance. It has bellowing features:

- Higher rotary speed, can reach up to 4000~5000rpm, smaller size, light weight and tight structure.
- Using air cooling system, single stage pressure up to 98kpa, don't need cooling water.
- Using advanced impeller, three lobe type, ensuring the higher pressure and larger flow rate during operation, and reliable performance.
- Using precision gears, stable performance, lower noise level, and longer service life.
- Advanced inlet and outlet silencer design, tight structure, reliable performance. It designed with v-belt auto-adjustment structure, easily for maintainance.

## OPERATION REQUIREMENT

- Medium conveying temperature should be lower than 40 °C
- Dust in medium should be less than 100mg/m<sup>3</sup>, diameter smaller than half of gap.
- Gear temperature during operation should be lower than 145 °C, lubrication oil temperature should be lower than 110 °C
- Operation pressure should be lower than pressure rise marked on the nameplate or pressure listed in this manual.
- The gap between impeller and casing, impeller and side plate, impeller and impeller have been adjusted before delivery, the gap should be kept when re-assembling.
- Lubrication oil level must be at the middel level of oil window.



If the gap is too big, it will effect the blower's specification; If it is too small, the impeller may corrosion with other parts.

## Blower Model

### HG-125 V

**HG** : Stands for Shandong Huadong.

**125** : Stands for blower size.

**V** : Stands for vacuum pump,if no "V", it means roots blower.

## OPERATION PRINCIPLE AND STRUCTURE

### Operation Principle

Roots blower belongs to positive displacement rotary blower. Atmosphere air come into blower through inlet silencer. The two impellers turn in anti direction, and put the air from inlet to outlet, then the air come out through outlet silencer, flesible joint, relief valve and check valve.

### Structure

Blower structure as bellowing Picture 1

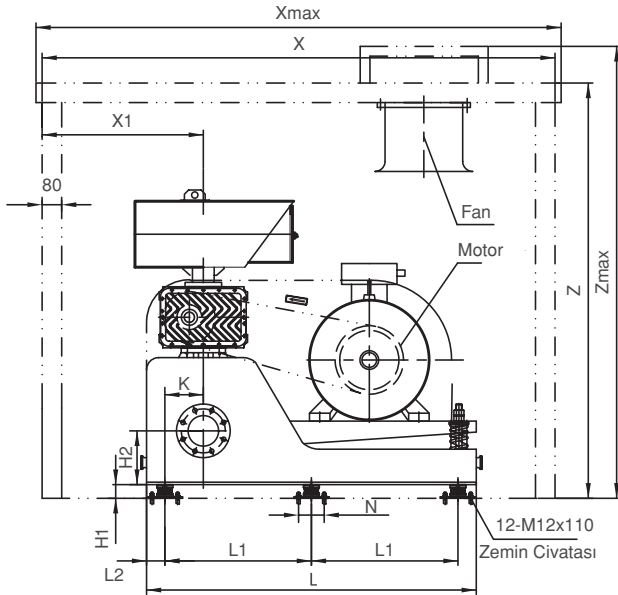

Picture 1

1 Motor,	4 Outlet Silencer,	7 Relief Valve Basement	10 Check Valve
2 Inlet Silencer	5 Vibration Absorber,	8 Relief Valve	11 Direct Pipe
3 Roots Blower	6 Flexible Joint	9 Pressure Gauge	12 Acoustic Enclosure



included in standard accessories, it is with acoustic enclosure.

## **Vibration Absorber**

There are vibration absorbers between blower basement and the ground. It can avoid blower vibrating and keeping blower operate smooth. At the bottom of absorber, there are flange to fix blower through steel material expansion bolts, easily for installation.

## **Belt Cover**

Belt cover is made with steel plate and plate with hole, better outlooks and good performance in ventilation.

## **V-Belt & Pulley**

This series roots blower trans with V type belts, tight structure and higher efficiency. Belt pulleys have passed the ballance test, smooth operation performance, lower vibration.

## **Blower**

HG series roots blower is on the basis of American HI-BAR company M series roots blower, and using our own design. It has a great improvement at structure and performance. Its structure as following picture 2: Blower casing is in one piece, taking use of high quality casting iron by resin sand casting, then process by imported CNC machining centers. Casing and side plates insisting the whole casing. 1. Side plate is in one piece, material high quality casting iron, process by imported CNC machining centers.

## **Impeller**

Impeller is in high quality casting product, using new impeller style, high using efficiency, lower inside leakage. The lobe and shaft are in one piece, having past the Magnetic particle inspection. Impellers have to pass the dynamic ballance test, precision class reach G2.5, ensuring the smooth rotation of impeller and lower vibration.

Synchronous gears: Synchronous gear is an important accessory of roots blower. Its material is in Chromium manganese titanium alloy steel, with carburization and quenching treatment, it is strong enough. After processed by high efficiency CNC machining centers, its precision grade can reach GB10095-88 5. Gear using lubrication oil. HG series roots blower using helical synchronous gears, operates smoothly and with lower noise level, service much longer time.

## **Bearings**

The bearings used for HG series blower are bearings that have past S0 dimension treatment, such as SKF or FAG bearings with splash lubrication.

## **Sealing**

Blower's side plate sealing is to avoid gas leakage from blower casing.

## **Oil Level**

There's an oil window at the oil tank, oil level should be kept at the middle position of oil window during operation. If the oil level is too high, it will cause oil temperature rise abnormally and oil leakage. If oil level is too low, it may damage the gears and bearings because of lacking lubrication oil.

## **Inlet Silencer**

The inlet silencer has filtration fuction, it can avoid dust or others come into blower casing and protect blower operate normally.



### **Outlet Silencer**

Outlet silencer of HG series is welded with base frame, hanging ring, motor guide and other parts, better and tighter structure, reduced blower's vibration and saving much more space.

### **Flexible Joint**

It can reduce blower's vibration and much more easily for installation.

### **Relief Valve**

HG series roots blower uses SV type relief valve, it can protect the blower.

### **Check Valve**

Check valve can avoid air return back to blower.

### **Pressure Gauge**

Pressure gauge can show the discharge pressure of blower.

## INSTALLATION & PIPING

### **Installation Place**

Blowers should be installed in bright and clean building. If it is put at outside, the protecting cover is necessary, especially for motor and v-belts.

The place should have enough space for disassemble, assemble or daily check, and better condition for ventilation.

### **Basement**

The ground basement should use concret. Considering about the weight of whole set roots blower and the tolerance of basement, the suggest concret is cement 1:sand 2: gravel 4.

Basement must be in horizontal level, error within 2mm/1m.

Basement height 50mm at least, avoid water or oil corrose the rubber vibration absorber. After

### **Installation**

Put blowers on the concret basement, after confirming the position, roling the holes for expansion bolts at basement. Put expansion bolts through the flange hole at the bottom of rubber vibration absorber, and fix the nuts.

To avoid damage blower because of starting blowers directly, and ensure the normal working of electricity, pls use a proper starter or other control equipment.

### **Piping**

Elbows are not suggest, and 90°elbow is forbidden, for they would increase the resistance of air conveying. What's more, there should be frame for pipes.

Before pipe assembling, pls check the blower inside casing, to make sure there's no dirt things inside blower, then connet the pipes with blower outlet. If there are dust, rust and some other dirty things inside pipe, pls remove them all and then connet them with blower. It is not allowed for air leakage between flanges.

The filter at blower inlet is necessary, and keep it clean. If the resistance of blower increases too much, pls check the inlet filer and clean it."

At blower's outlet side, relief valve is necessary, too. It is used for protecting blower when the pressure rise too much in short time. Check valve is to avoid air return back to blower and damage it. If the blower is used for vacuum pressure, the vacuum relief valve is necessary.

The relief valve or vacuum pressure relief valve have already adjusted before delivery out from our factory, users don't need to re-adjust it. To ensure the blower's normal operation, the relief valve should be nearer to the blower than check valve.

Pressure gauge is assembled at the roots blower's outlet and vacuum blower's inlet side. The gauge's rise should be suitable for the project's requirement.

### Methods For Adjust The V-Belts

HG series roots blower us narrow V type belts for transmission.

The tight or loose of v-belts have direct relationship of blowers normal operation and belts & bearings service life. Normally, pls adjust the belts according to Picture 3 as bellowing. If the power W fits for Chart 1, then the belt is ok. If the power is smaller or bigger, then it shows the belt is too loose or too tight, you should adjust it.

As Picture 2, put a power "W" at "a" position, which is in vertical direction to belt, when the deflection  $\delta=0.016a$  mm, the belt power "W" should fit for Chart 1.

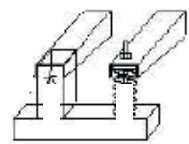

Picture 2

### LUBRICATION OIL

Pls use professional lubrication oil for HG series roots blower, suggest Mobile SHC 630, or Shell Omala RL 220. If use other brands, it may damage the blower.

Blower model	HG-50 HG-65	HG-80 HG-100	HG-125 HG-150	HG-200 HG-250
Oil tank at gear side (L)	0,4	1,46	3,4	8,88
SOil tank at driven side (L)	0,22	0,69	1,6	4,16



Pls remove the wood before adjust belts.

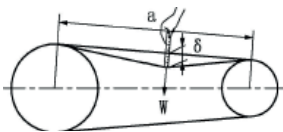

Picture 3

Belt Size	SPZ	SPB	SPC
Min.	11	34	64
Max.	18	47	90

Pls keep the central points of two pulleys are in one level, in this way, it can make sure that the belts inside pulley won't damaged in one side. Bellowing pictures show two pulleys don't in one level:  $e \leq 1000 \times a$  (means the distance between central points of two pulleys), and two pulleys in different direction:  $\beta \leq 20'$



Picture 4

Pls change all belts when users change belts, it is not allowed to use new belts and old ones together. And oil for belts and pulleys are not allowed, too. Belt and pulley cover is necessary, and keep ventilation.



Pls put the cover before using!

## OPERATION TIPS

### Preperation For Operation

Pls remove or the dust or other things inside or outside blower, and avoid oil come into blower casing. Check blower inlet and outlet connection loose or not, as well as the frame for following pipes.

Make sure the oil level is in the middle level of oil window( add oil upto the middle level, it would be a little different when blower running. You can add or less oil to keep it in the right level.) If oil is less, it would damage the bearing and gears for lacking lubrication. If there are too much oil inside oil tank, it may cause oil temperature rise too much and damage bearing and gears, too.

Lubrication oil for HG series roots blower should be professional oil for blower, suggest Mobile SHC630 or Shell Omala RL 220 gear oil, density grade ISO VG220. The capacity of lubrication oil pls refer to Chart 4 at P10 of this manual. After finishing adding oil, pls tight and seal the oil drain plug.

The position of adding or less oil refer to P11 of this manual.

Pls don't add oil during blower operation process. After the first month of blower operation, change the new lubrication oil for blower. Then change oil once a year if you use suggest lubrication oil.

To pull the pulley of blower side to check whether it works normally or not.

### Test Running

Test running is necessary for new blower, or blower after repair, or blower rest for a long time.

Open the valve at blower outlet, turn on the power switch with no loading for blower, and check the rotary direction.

Running for 20 ~ 30 minutes after starting, and check blower have abnormal vibration or heating condition. If these conditions appear, stop blower running and check out the reason. They may be caused by un-proper installation methods or un-proper lubrication oil level.

After blower running in good condition, running it for 2 ~ 3 hours, and pay attention to temperature and vibration.

Pay attention to the electric current during operation, if it shows abnormal, pls stop operation and check. Most of such condition caused by heavy loading or impeller friction.

### İşletme Sırasındaki Notlar

Check the temperature of bearings and lubrication oil, as well as the electric current. Check the numbers regularly and take notes. When stop running blower, pls relief pressure first and stop blower. Pls start blower without load.



Don't touch the hot surface! Don't start or stop blower with loading! Ear protect is necessary!

## MAINTAIN AND REPAIR

### Daily Maintenance

Stop blower and check it if there are abnormal vibration or heating at blower casing, side plate or oil tank.

Pay more attention to temperature of bearings, as well as its vibration and noise.

After long term operation, and rust at blower casing and impeller, the gap between impeller and casing increase, inside leakage increase, too. Then the temperature of blower casing and discharge air rise, the flow rate reduce. Under such condition, pls stop blower and check the gaps, if it is abnormal, re-adjust it.

Check the oil level.

Check the pressure of inlet and outlet, to ensure the blower operate normally. Check motor loading. If it increase, means there's something wrong, should stop blower and check the reason.

### Regularly Check

Monthly: The loose or tight condition of v-belts.

Half year: the quality of lubrication oil, and the frame of pipes. Year: the bearings, sealing rings, impeller and casing, gears.

Change new lubrication oil according this manual.

### Disassembling

Notes during disassembling process: all connection parts should mark out. Don't damage the sealing rings at connection parts.

Test the depth of sealing rings when disassemble.

Kepp accessories clean, especially bearings, avoid rust and dust.

### Assembling

Notes during assembling:

Confirm the disassembling accessories ok or not. Cleaning the disassembling accessories.

Check the depth of parts. Make sure the depth and material of parts are same.

### Adjustment Of Gap

The gaps of blower have tight relationship with blower's performance and serving life. And they are already adjusted before delivery out from factory, so users can't changed it by yourselves. If you want to adjust the gaps, pls under our guidance.

Gap adjustment of impellers:

Loose the expansion ring at driven shaft gear, knock the impeller with rubber hammer or copper rods, to make the gaps fitting for standard, then tight the expansion ring.

Gap adjustment of impeller and casing:

Through increase or decrease the depth of part between fixing bearing and oil sealing to adjust the gap.

## PROBLEM ANALYSIS AND REPAIRS

Main problem of blower & vacuum pump, reason and repair methods, as Chart 2.

Problem	Reason	How To Solve
Flow Rate Too Small	Impeller Gap Increase.	Re-Adjust The Gap.
	Belt Loose.	Tight The Belts.
Motor Overload	Inlet Filter Or Pipe Clogged.	Clean Dust Inside Filter Or Pipe.
	Impeller Friction.	Re-Adjust The Gap.
Over Heating	Too Much Lubrication Oil Inside The Main Oil Tank.	Adjust The Oil Level.
		Reduce The Resistance Of System, And Reduce The Pressure Rise.
		Adjust The Gap.
Knock Noise	Gear Or Impeller Moved.	Re-Adjust Position.
	Assembling Problem.	Re-Assembling.
	Pressure Rise Abnormal.	Check The Reason For Pressure Rising.
	Overloading Or Gear Damage For Lacking Lubrication.	Change New Gears.
Bearing / Gear S Damaged Badly	Low Quality Of Lubrication Oil.	Change Better Lubrication Oil.
	Lacking Lubrication Oil.	Add Lubrication Oil.
Shaft Or Lobe Damage	Over Loading.	Make Sure The Reason For Overloading And Reduce It.
	Air Back Into Blower From System.	Check Our The Reason For Air Back.
Vibration Badly	Impeller Balance Damaged.	Check Reasons.
	Bearings Damaged.	Change Bearings.
	Gears Damaged.	Change Gears.
	Fixing Bolts Loose.	Tight The Bolts.
	Rubber Vibration Absorber Damaged.	Change Rubber Vibration Absorbers.
Relief Valve Don't Work	Pressure Setting Wrong.	Re-Set Pressure.
	Spring Don't Work.	Change A New Spring.
Pressure Gauge Don't Work	Pressure Gauge Damaged.	Change A New Pressure Gauge.

## ACCESSORIES

Control box and acoustic enclosure are equipped as users need.



Bearings must use SKF or FAG brand passed S0 dimension treatment.

## PROFESSIONAL SYSTEM SOLUTION CENTER

From our MIT professional system solution center, you can get help with problems with your pumps, heat exchangers and your system. Our solution center consisting of our expert engineers will be happy to help you.

- Domestic hot water installations.
- Central and district heating systems.
- Milk, yogurt, buttermilk heating, cooling and pasteurization systems.
- Industrial cooling and heating systems.
- Oil cooling systems.
- Energy recovery systems.
- Pool heating systems.
- Steam installations.



It is vital for your system to be designed and implemented correctly in the first installation in order to be able to operate at the desired capacity, smoothness and long life. For this reason, you can get

first-hand the technical support you need during the installation phase of your system and the problems that may arise in the business; You can reach us **24 hours (216) 444 35 46 in 7 days.**

We would like to reiterate that we will be happy to share our knowledge accumulated over many years with our valued customers in order for your system to work correctly and performance.

Ekin will continue to be the best solution partner for you in all applications with all kinds of heating and cooling applications.



**444 35 46**



/ekinendüstriyel

Follow us on  
social media...



Our products are produced with Turkish engineering technology in **135 countries** in the world today...

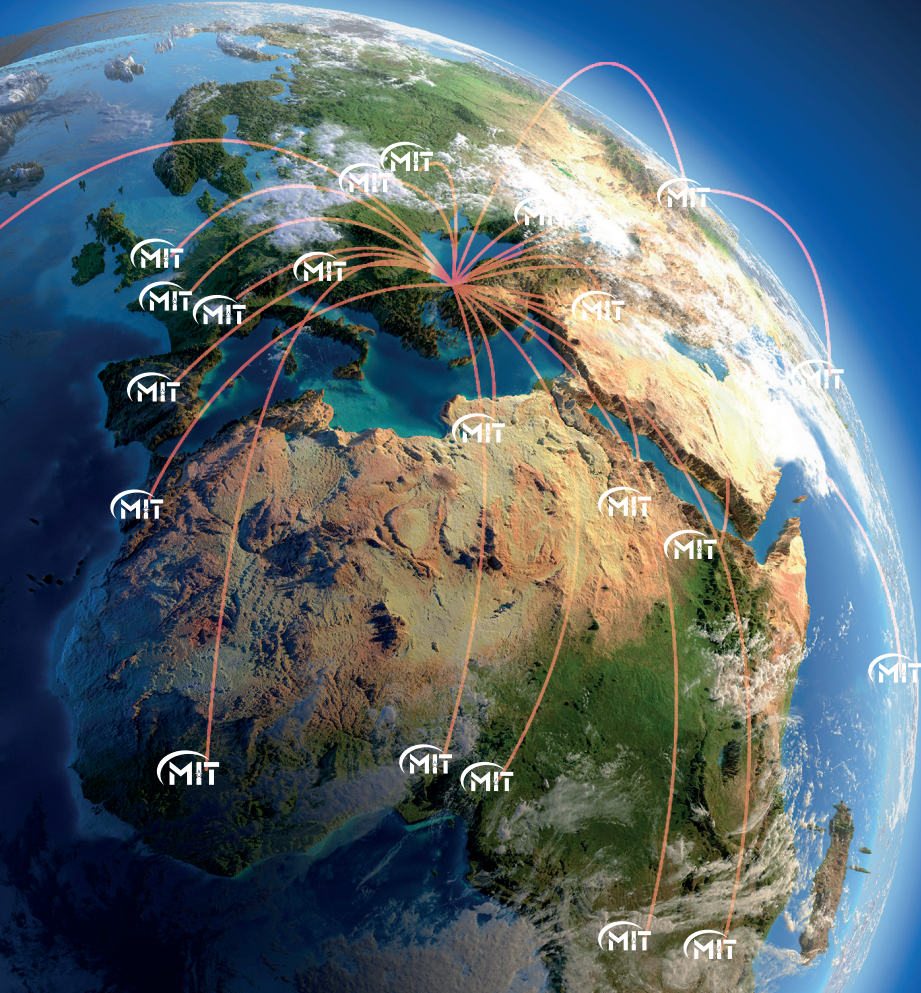

444EKİN  
3546

 **EKİN ENDÜSTRİYEL**  
Isıtma-Soğutma San. Tic. Ltd. Şti.

Dudullu Organize Sanayi Bölgesi - Des Sanayi Sitesi  
107. Sk. B14 Blok No: 2 Ümraniye / İstanbul / Turkey  
**Phone:** +90 216 232 2412 **Fax:** +90 216 660 1308  
[info@ekinendustriyel.com](mailto:info@ekinendustriyel.com)-[www.ekinendustriyel.com](http://www.ekinendustriyel.com)